

CONSIGLI DI INSTALLAZIONE E MANUTENZIONE /RECOMMENDATIONS FOR INSTALLATION AND MAINTENANCE

BLÒ1-BLÒ2 - COLLEZIONE MARATHI /MARATHI COLLECTION BLÒ1-BLÒ2

Design: Emanuele Montanelli. All rights reserved. Made in Italy

1. Si declina ogni responsabilità relativa alle eventuali inesattezze contenute in queste informazioni che sono consigli utili per il montaggio del prodotto, che dovrà essere eseguito da installatore specializzato. Maneggiare sempre con cura ogni componente del prodotto. */The company declines any responsibility for inaccuracies in the present information providing suggestions useful for installation of the product. Remember installation must always be performed by a skilled installation technician. Always handle all product components with utmost care.*
2. Tulli Zuccari invita il cliente a controllare l'integrità dei componenti contenuti nell'imballo prima del montaggio e comunicare immediatamente eventuali difetti. */Tulli Zuccari invites you to check that the components contained in the package are intact before installation and immediately communicate any defects found.*
3. Gli specchi BLÒ1 e BLÒ2 sono un prodotto artigianale: le fasi di lavorazione sono eseguite a mano, pertanto piccoli imperfezioni riscontrabili non sono da considerarsi come difetti di produzione. */BLÒ1 and BLÒ2 mirrors are an artisan crafted product: the processing phases are performed by hand; for this reason the minor imperfections found cannot be considered production defects.*
4. Tulli Zuccari srl si riserva il diritto di apportare in qualsiasi momento modifiche tecniche, costruttive, dimensionali utili al miglioramento dei propri prodotti, senza obbligo di preavviso o di sostituzione. */Tulli Zuccari srl reserves the right to make any technical, construction, dimensional modifications it deems fitting to improve its products at any time and without being required to give prior notice or make replacements.*
5. Il montaggio del prodotto deve essere eseguito da un installatore specializzato. Si consiglia di verificare l'idoneità dell'impianto elettrico esistente nel locale alle norme di sicurezza vigenti. */Product installation must be performed by a skilled installation technician. We recommend checking that the electrical system in your room meets the currently applied standards.*
6. Lo smaltimento dell'imballo e del prodotto alla fine del suo utilizzo deve essere realizzato secondo le modalità previste dall'azienda di smaltimento rifiuti competente sul territorio ove è installato il prodotto. */Always dispose of packaging, and the product when it is no longer used, in compliance with the standards in force and applied by the competent waste disposal company operating in the territory where the product is installed.*
7. Tulli Zuccari srl. declina ogni responsabilità per un uso improprio del prodotto, per danneggiamenti a cose o persone dovute al non corretto montaggio del prodotto, o alla rottura accidentale o casuale dello stesso. */Tulli Zuccari srl declines any responsibility for improper use of the product, property damage or injury due to incorrect installation or accidental breakage of the product.*

BLÒ1-BLÒ2

SPECCHI CONTENITORI /STORAGE MIRRORS

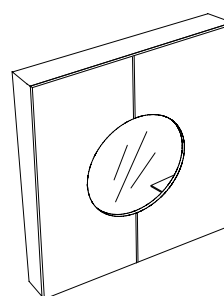

Blò 1
specchio /mirror
L80 P12 H80

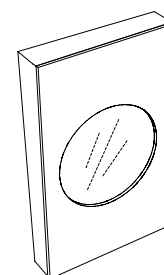

Blò 2
specchio /mirror
L56 P12 H90

Per maggiori informazioni contattare: customer@tullizuccari.com
/For further information please contact: customer@tullizuccari.com



Tulli Zuccari Srl. - Zona Industriale Bevagna (PG) ITALIA
T +39 0742 362040 F +39 0742 361936 - www.tullizuccari.com

SCHEDA TECNICA DELLO SPECCHIO

- Per installare correttamente lo specchio utilizzare la scheda tecnica corrispondente alla tipologia di specchio scelto (vedi da pagina 3 a pagina 4)

TECHNICAL FORM OF THE MIRROR

- *For a proper installation of the mirror, use the technical form corresponding to the type of selected mirror (see from page 3 to page 4).*

MANUTENZIONE E PULIZIA DEL PRODOTTO

- Per la pulizia delle superfici laccate o in essenza utilizzare esclusivamente acqua con sapone liquido neutro. Evitare l'impiego di solventi, abrasivi e prodotti acidi
- Per la pulizia dei top in vetro utilizzare alcool etilico o prodotti per vetro in commercio. Evitare l'impiego di solventi, abrasivi e prodotti acidi

PRODUCT MAINTENANCE AND CLEANING

- *To clean the lacquered surfaces use only water and a neutral liquid soap. Avoid the use of solvents, abrasives and products containing acids*
- *To clean a glass top use ethyl alcohol or other glass-cleaning products on the market. Avoid the use of solvents, abrasives and products containing acids*

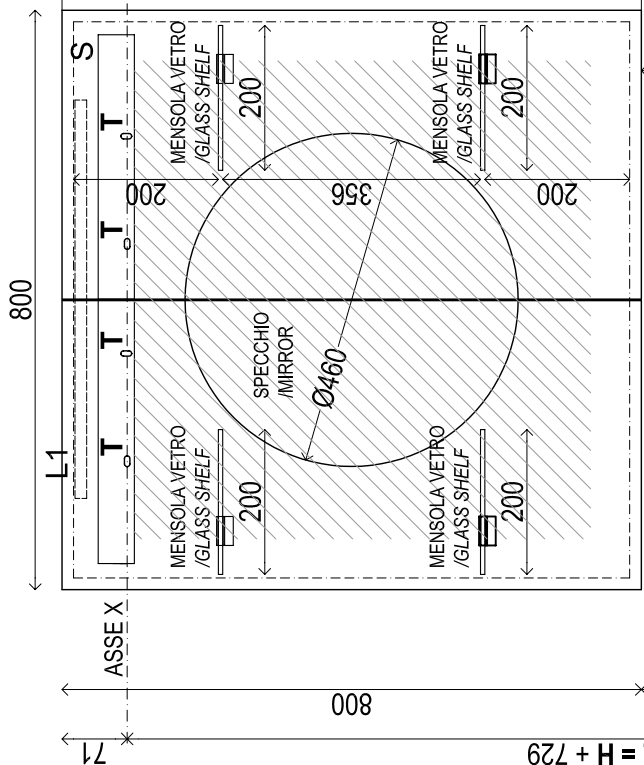
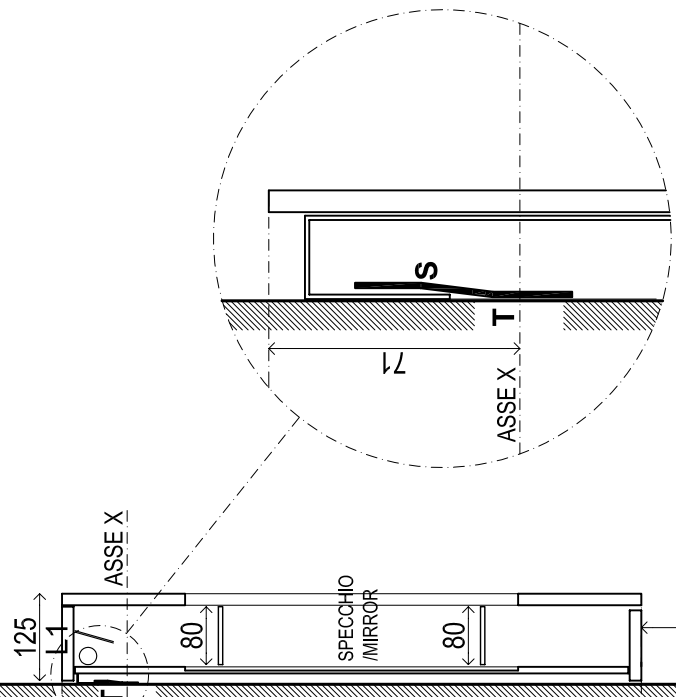
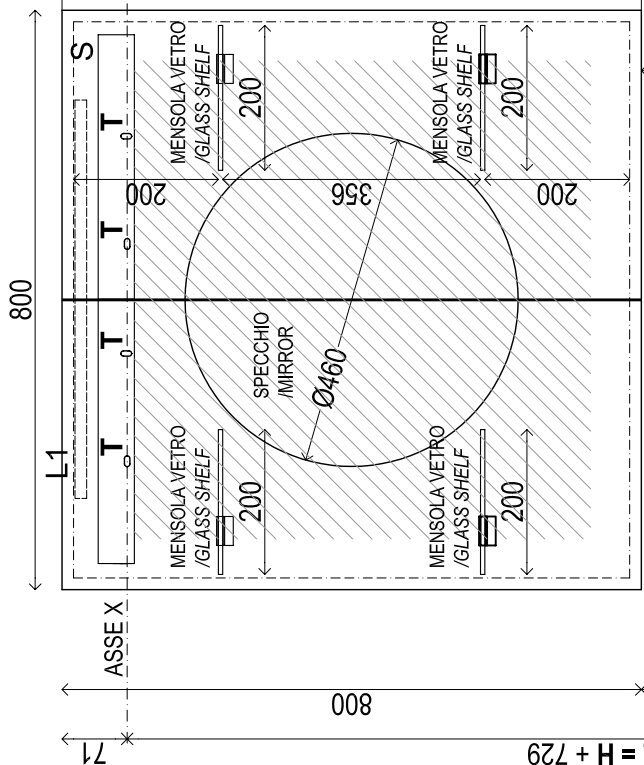
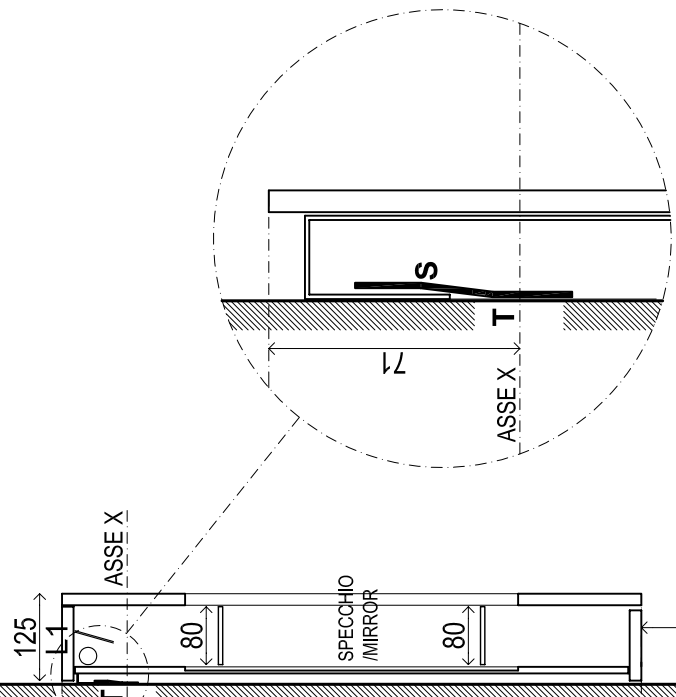
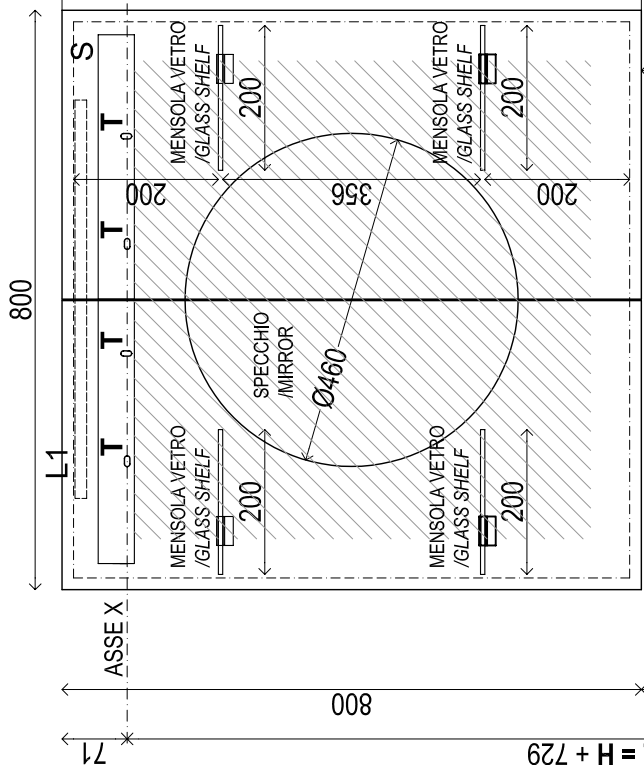
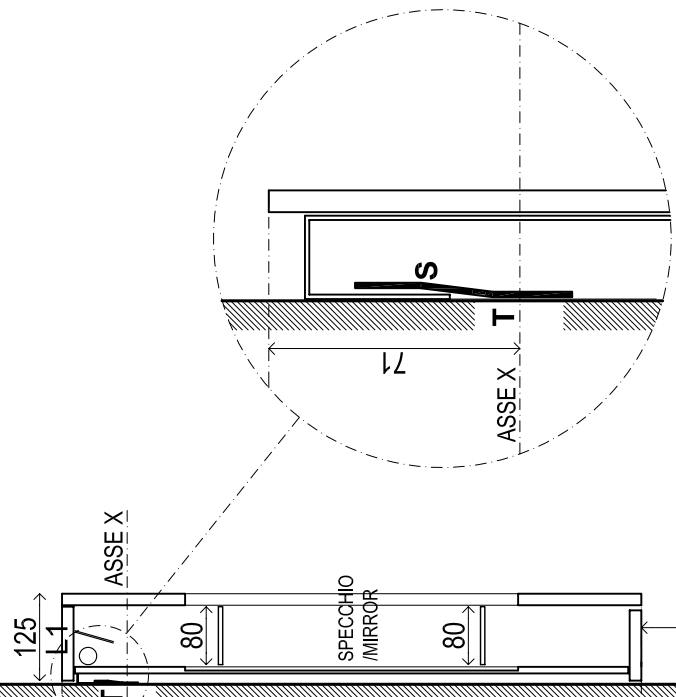
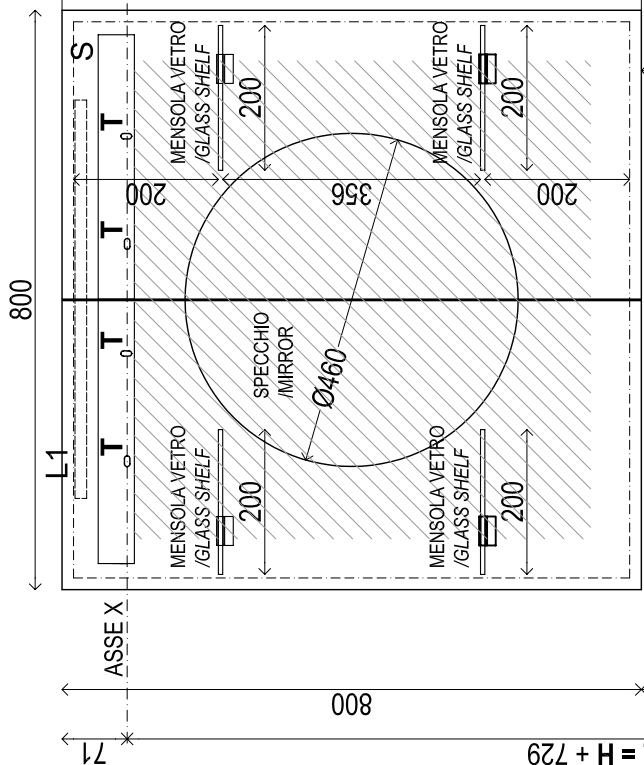
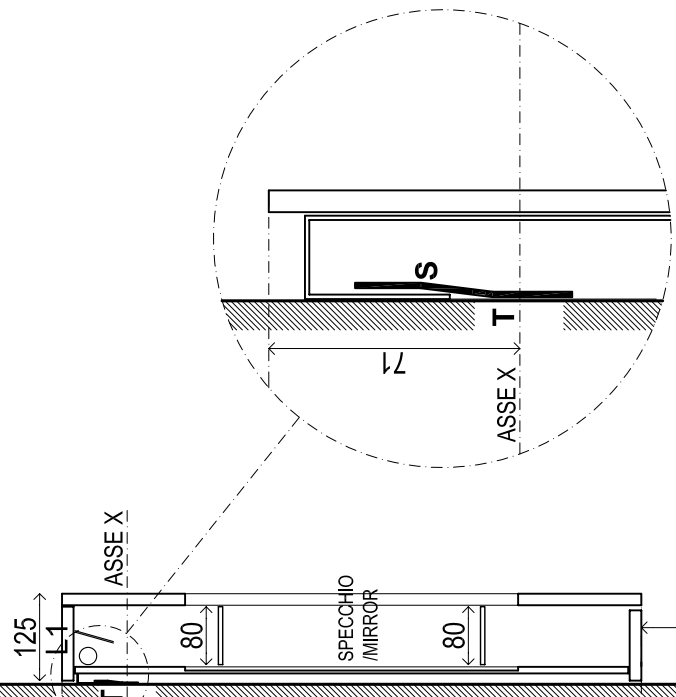
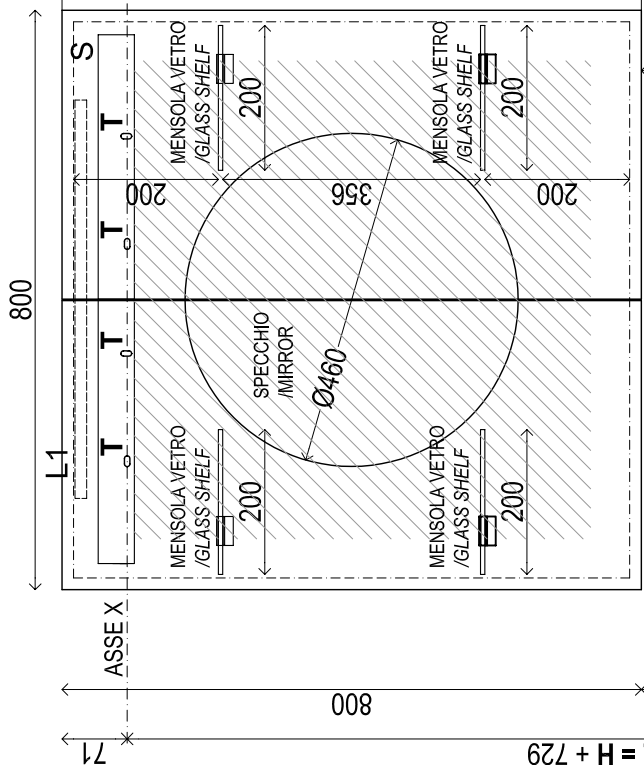
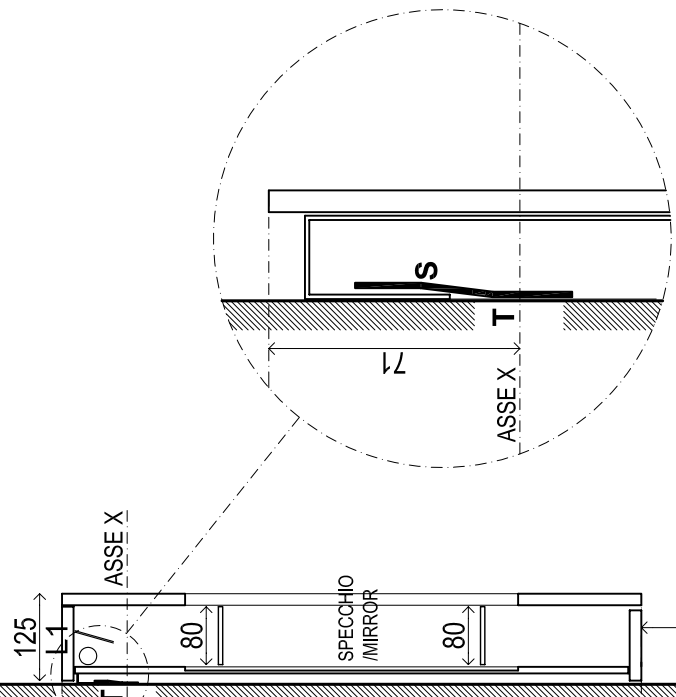
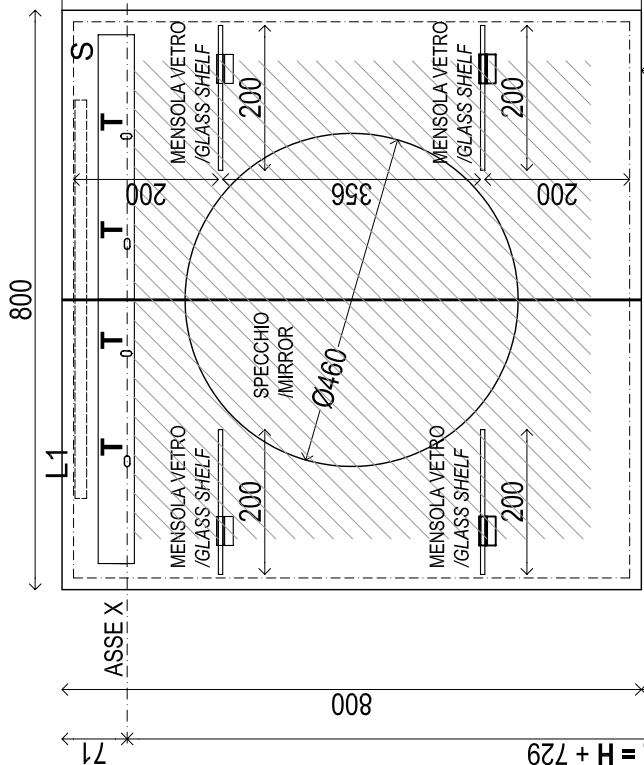
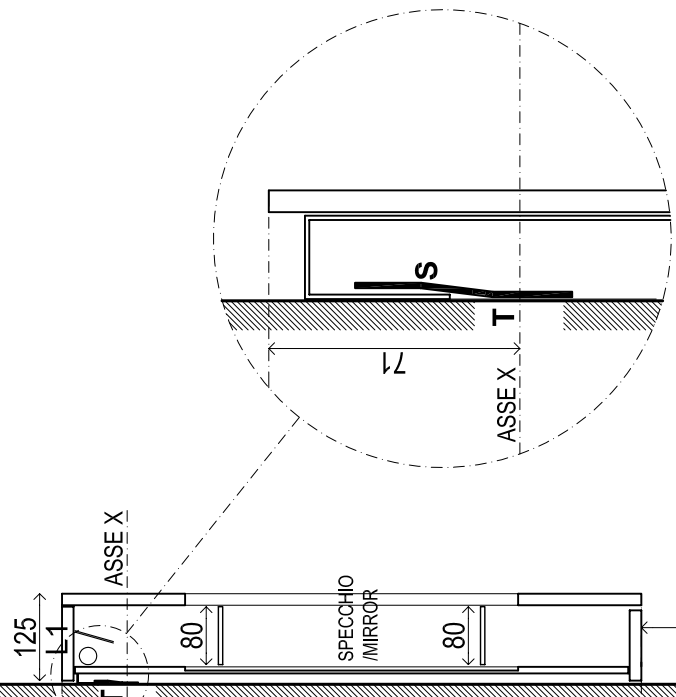
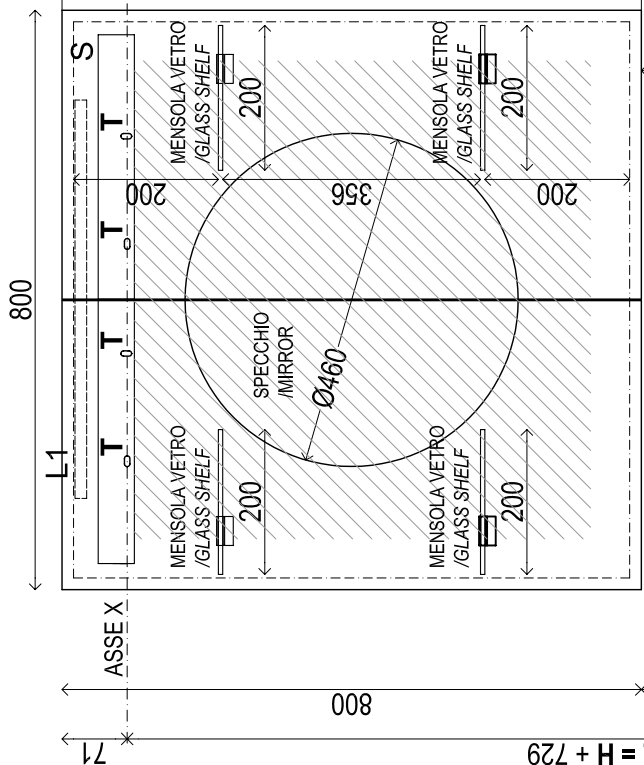
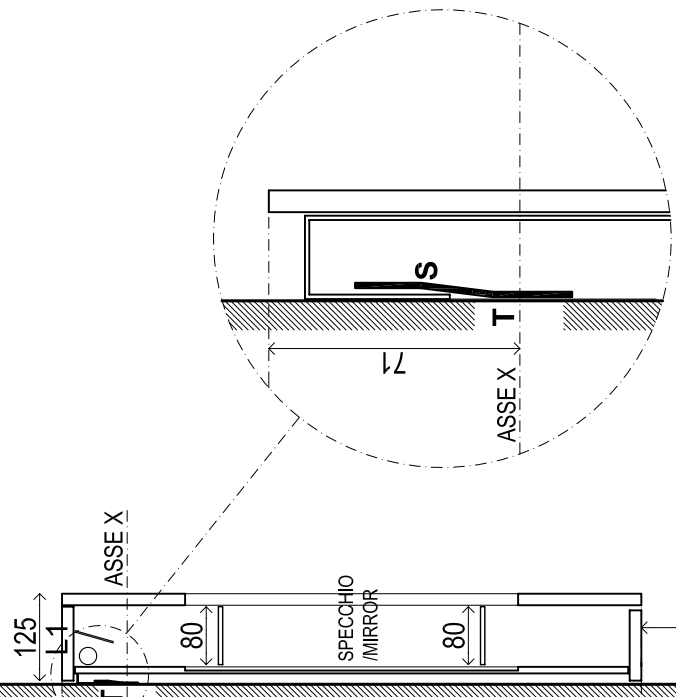
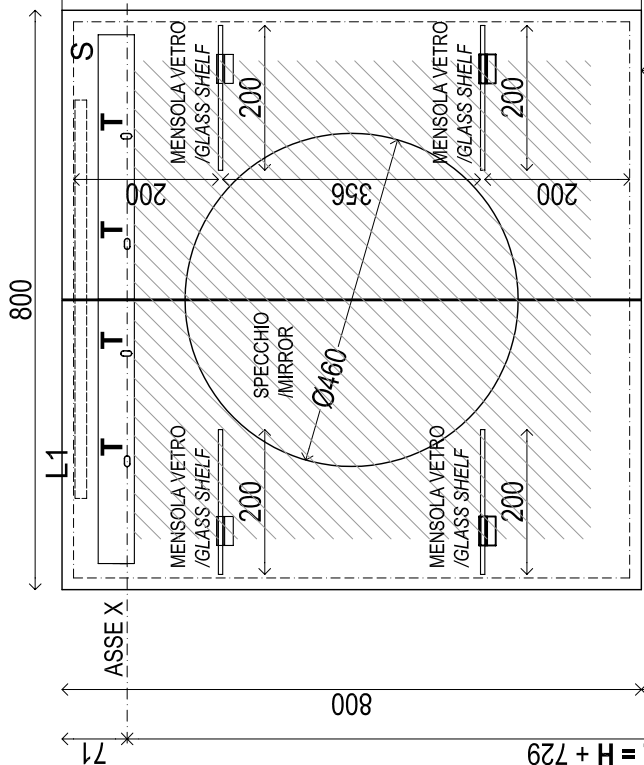
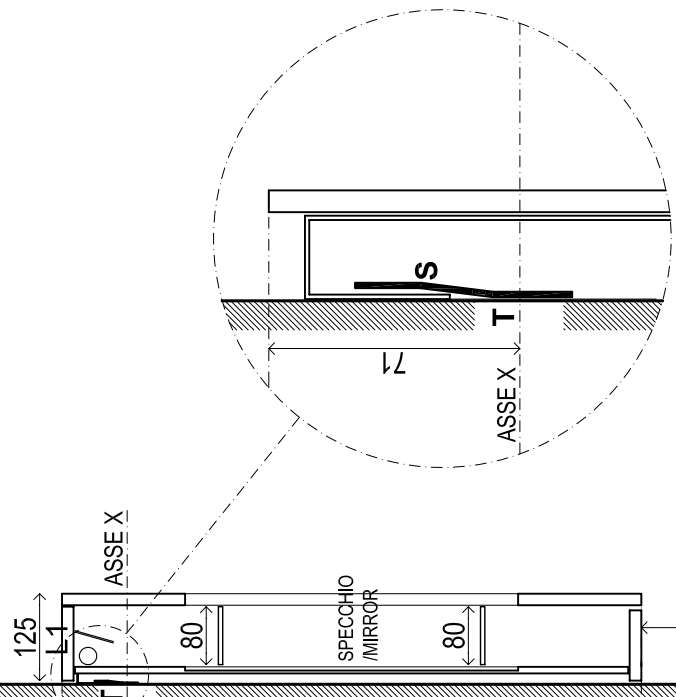
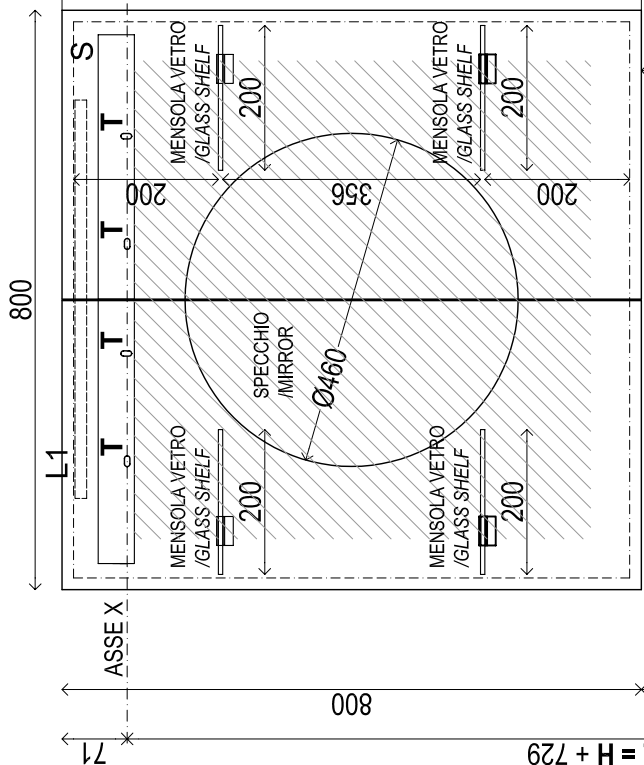
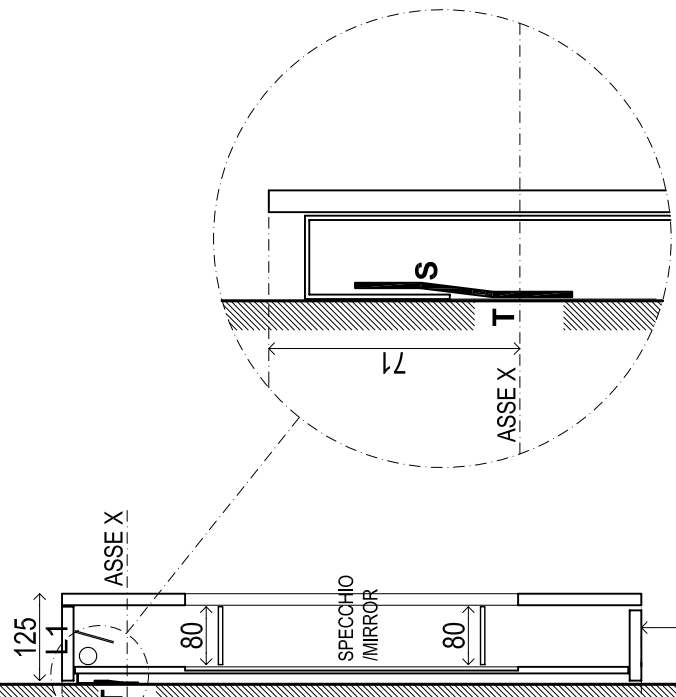
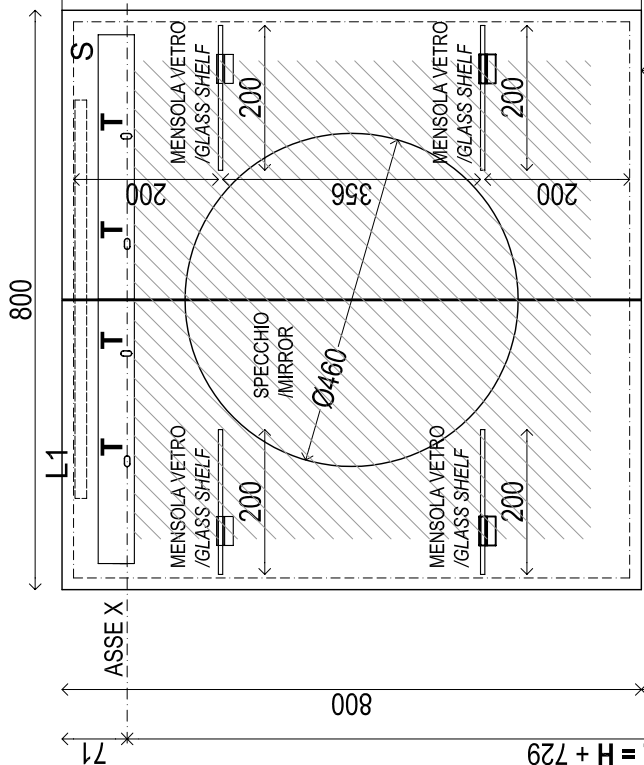
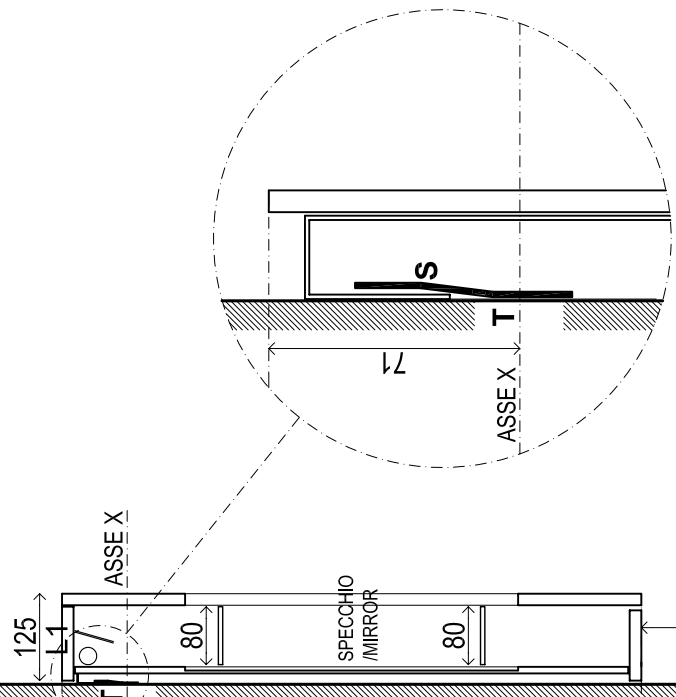
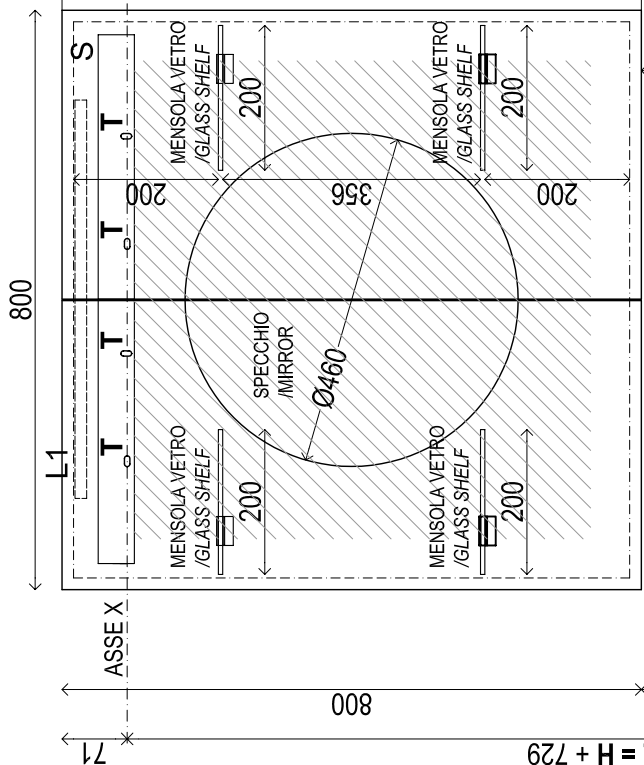
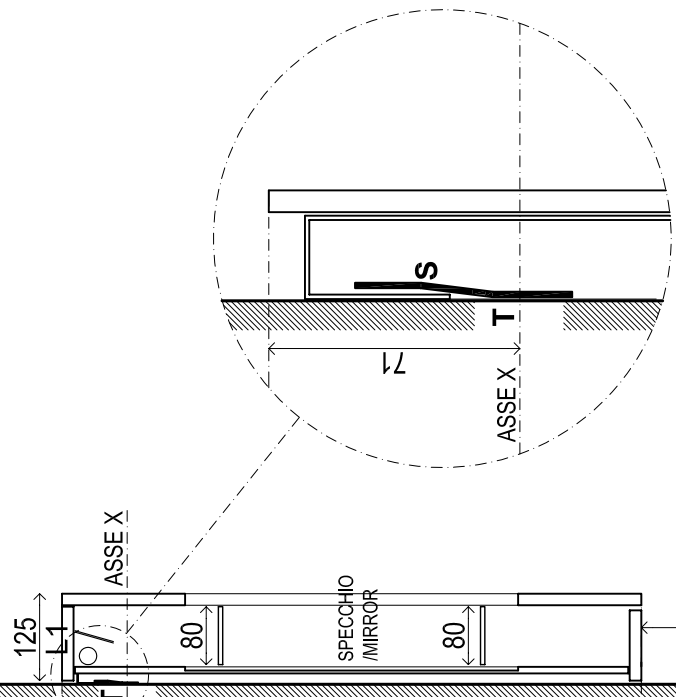
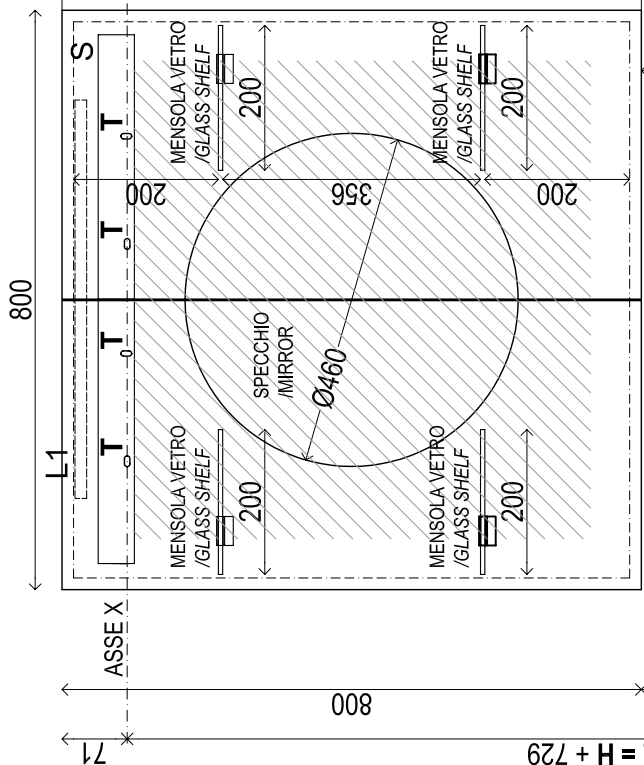
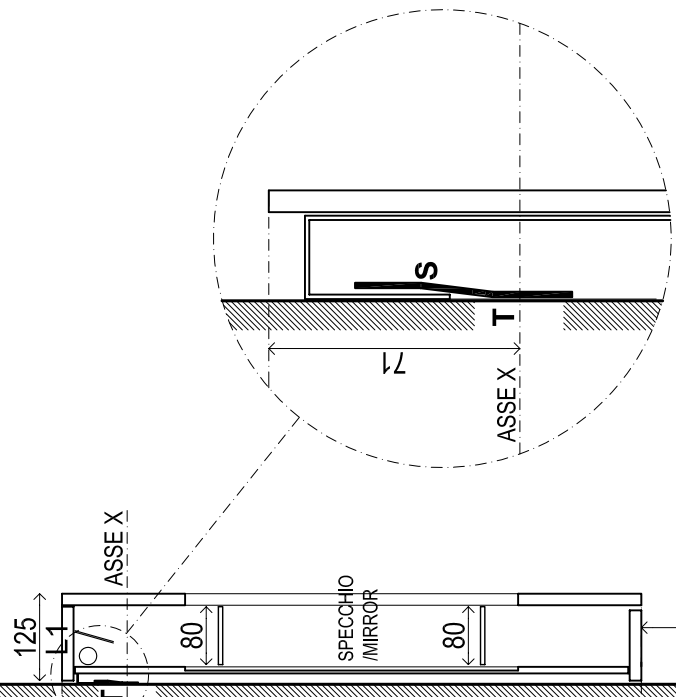
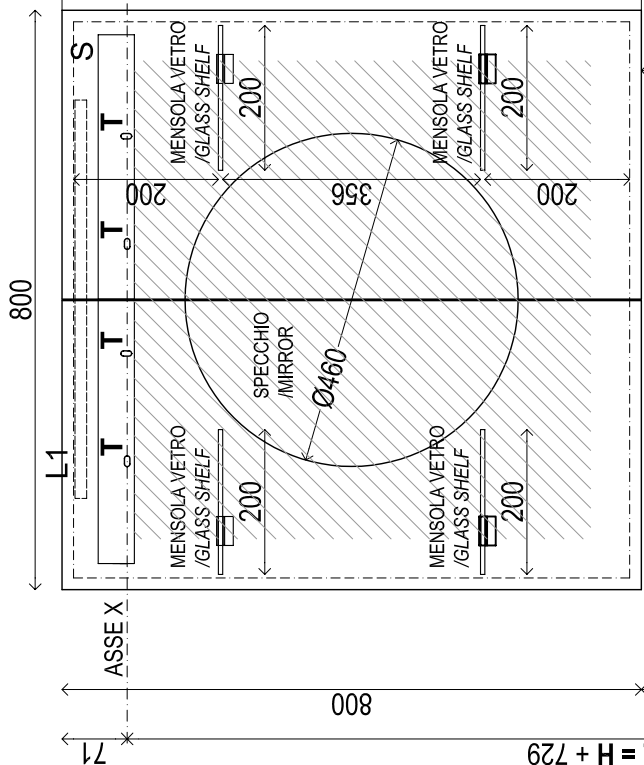
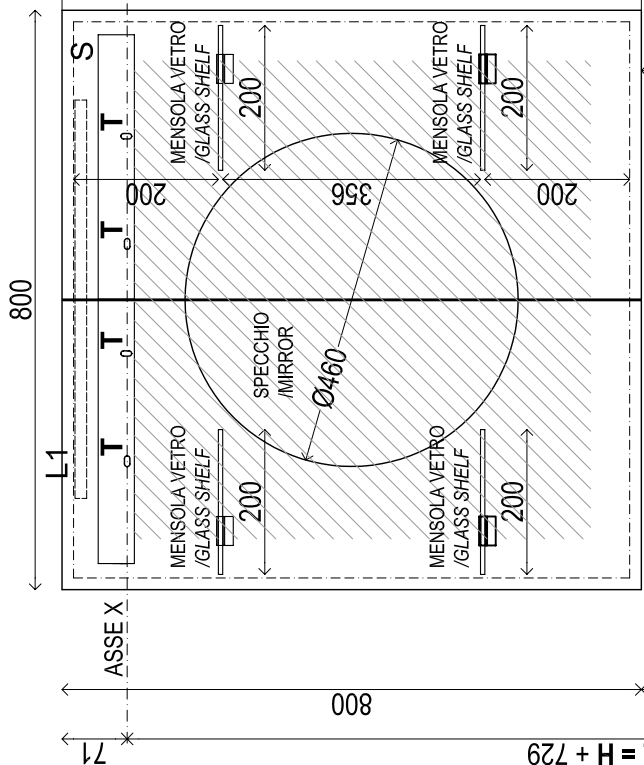
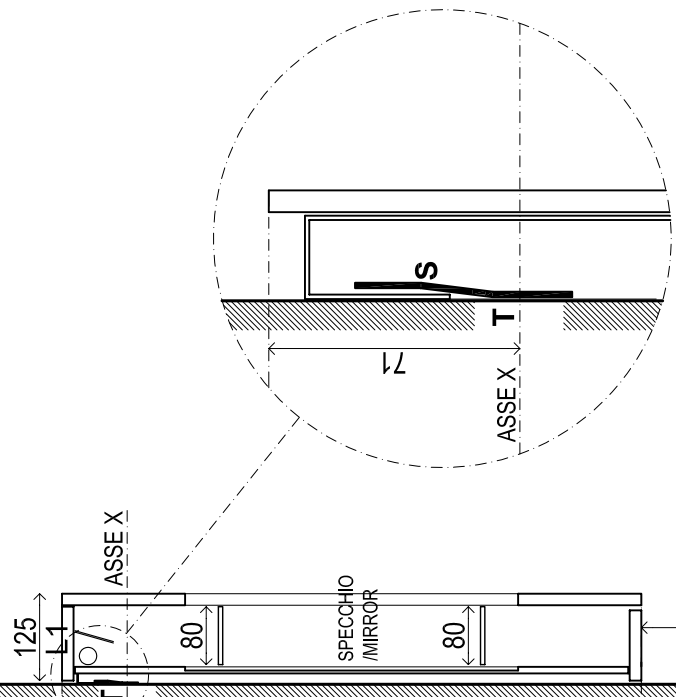
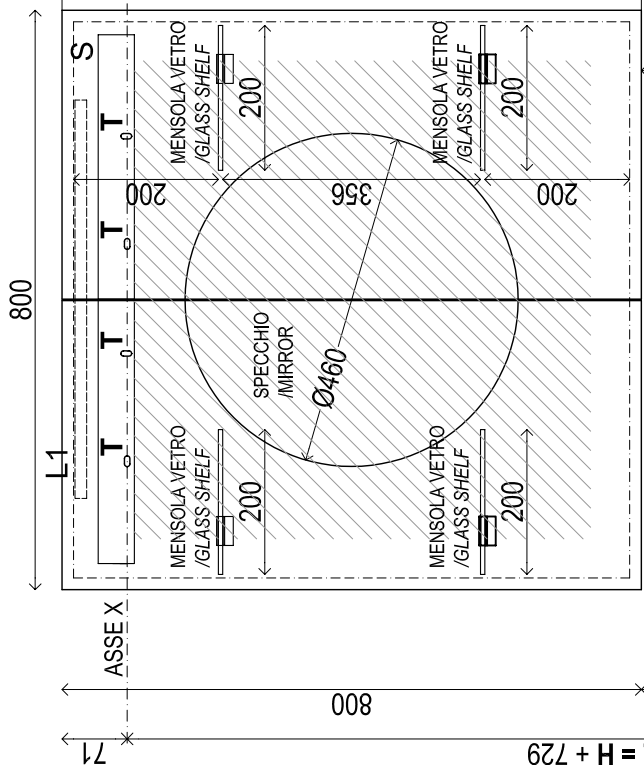
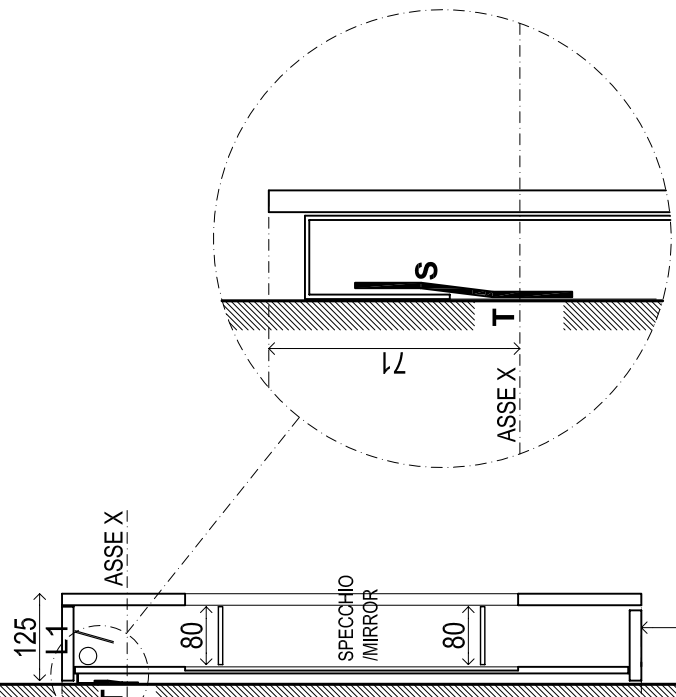
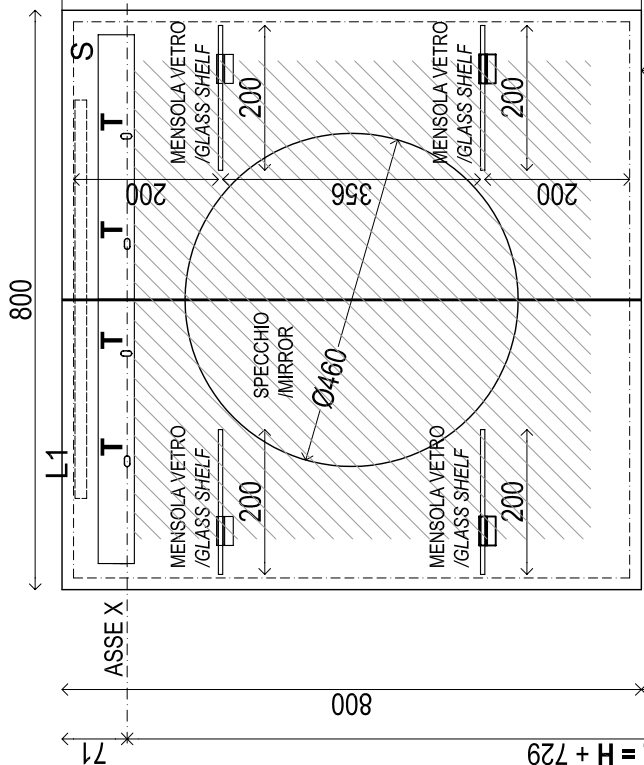
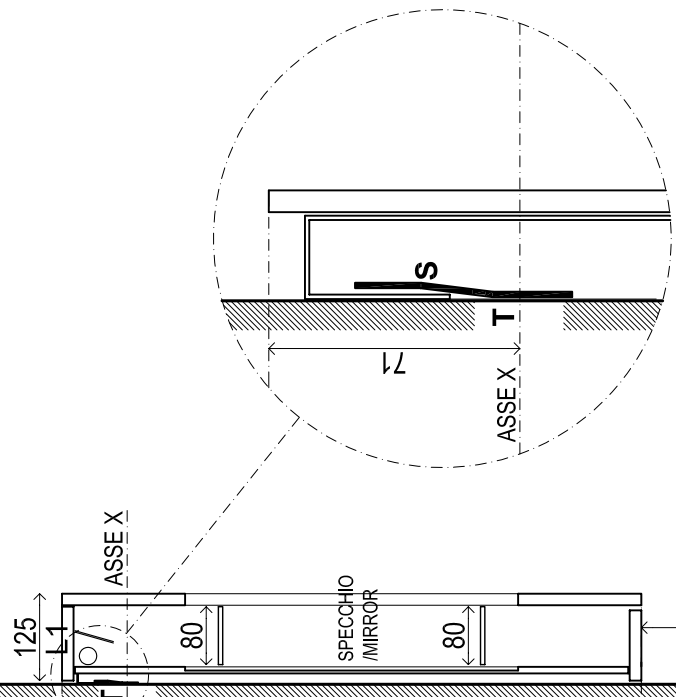
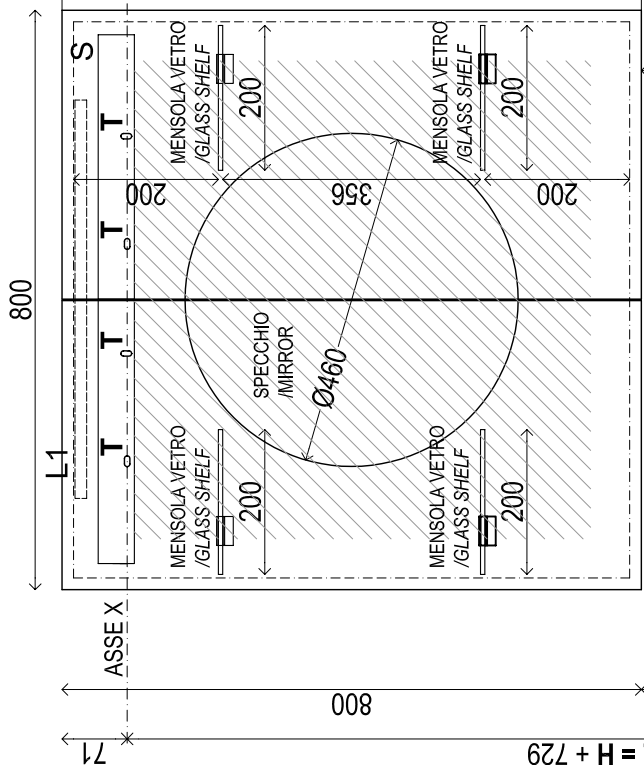
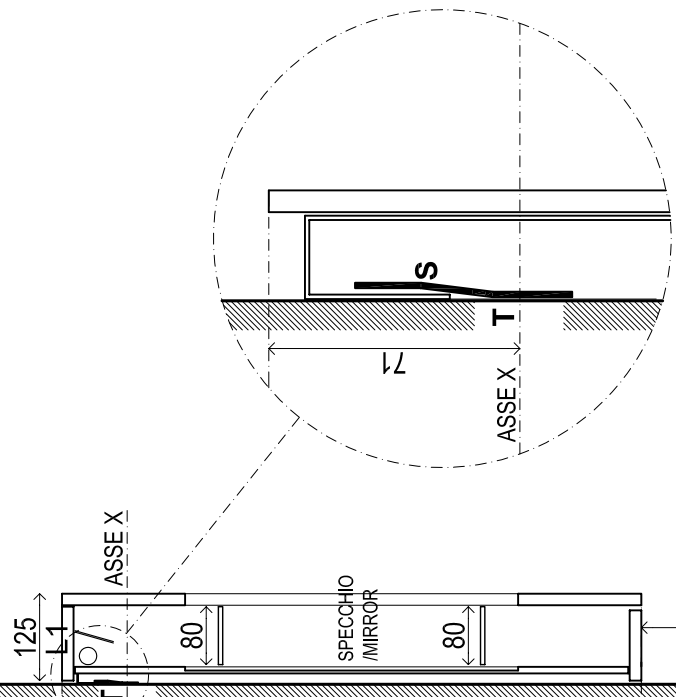
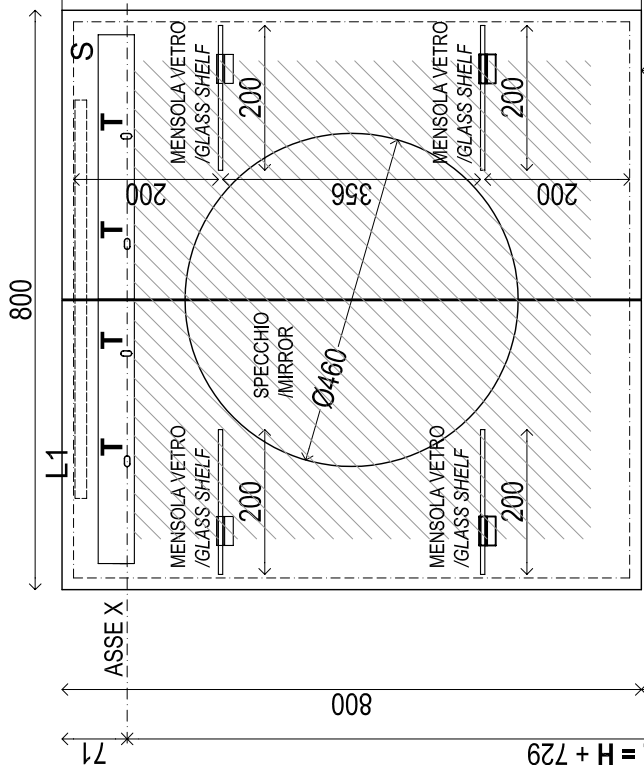
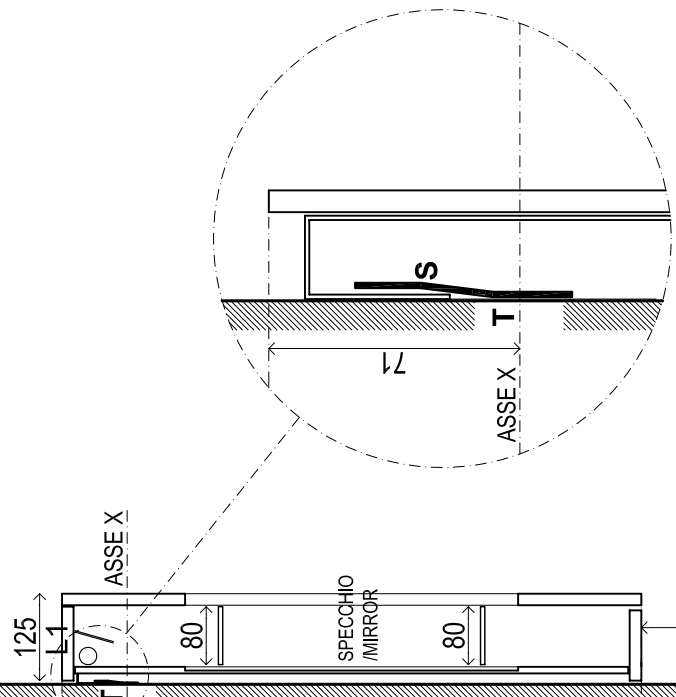
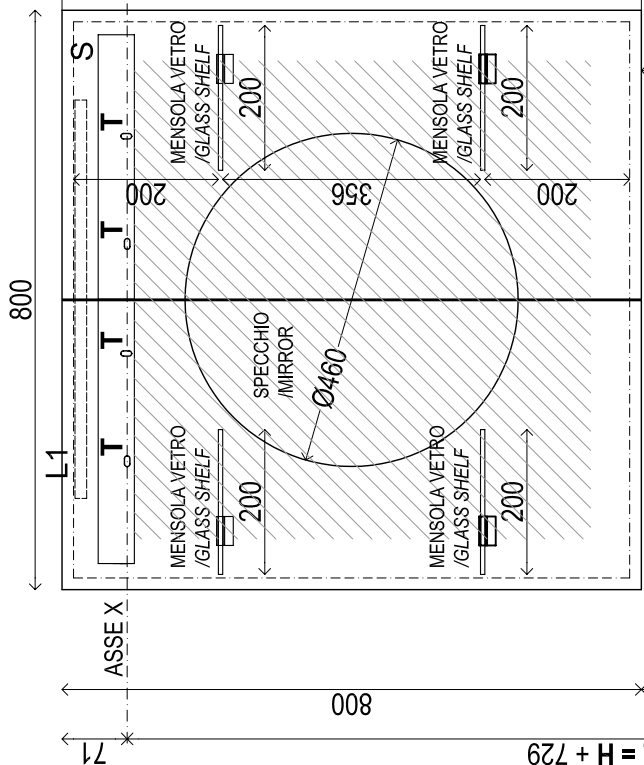
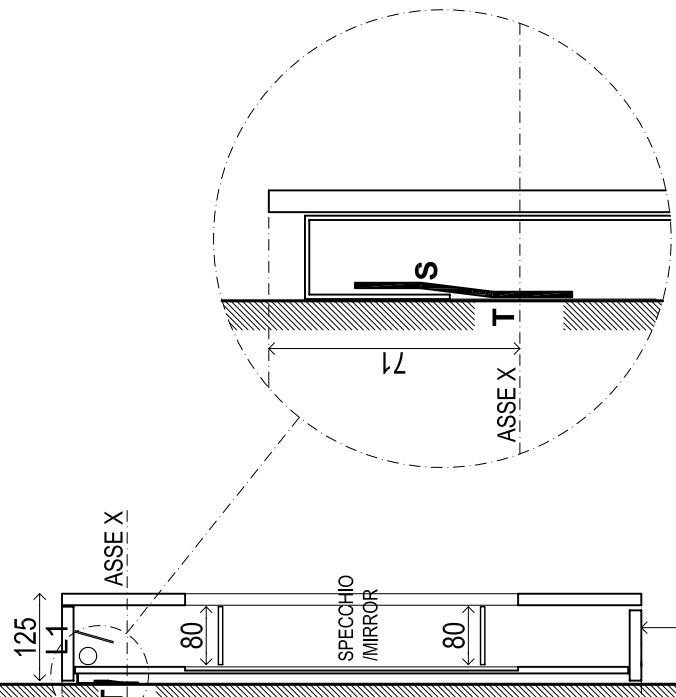
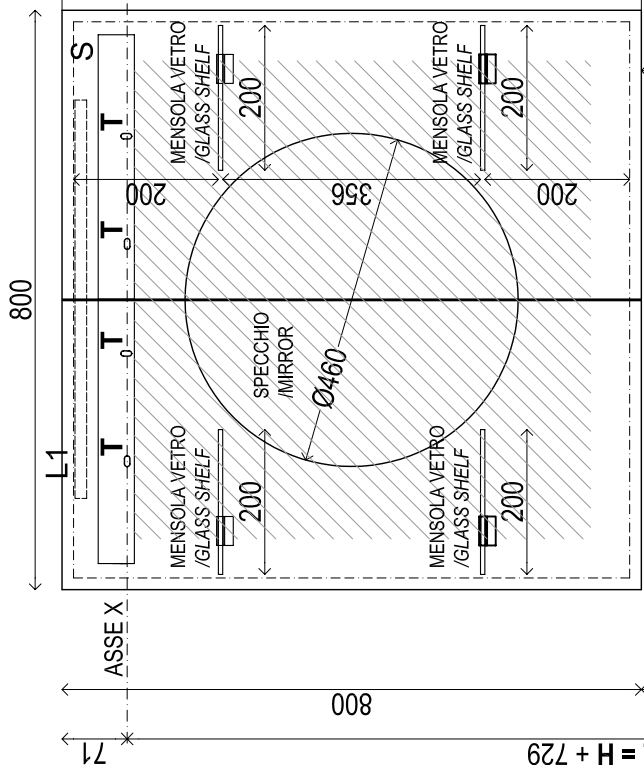
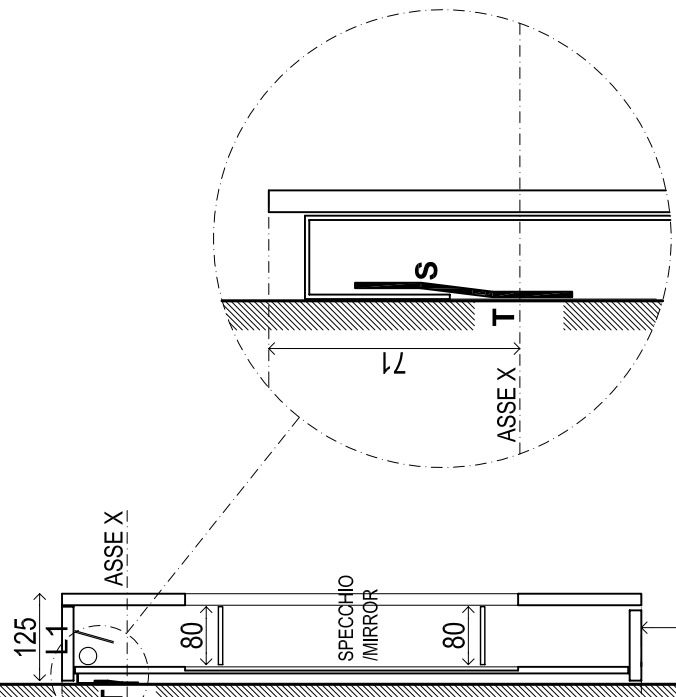
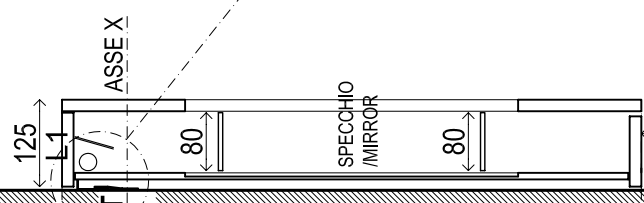
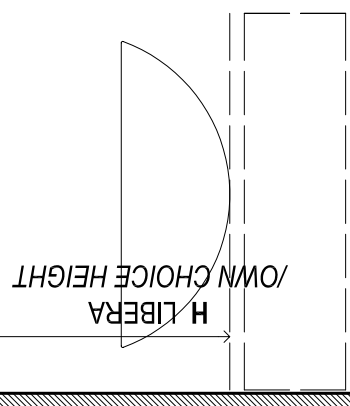
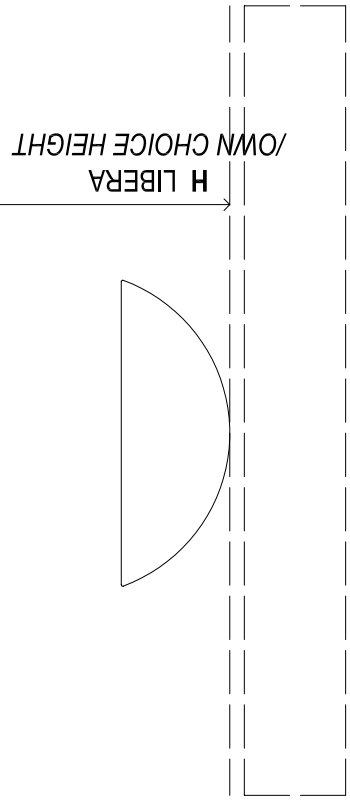
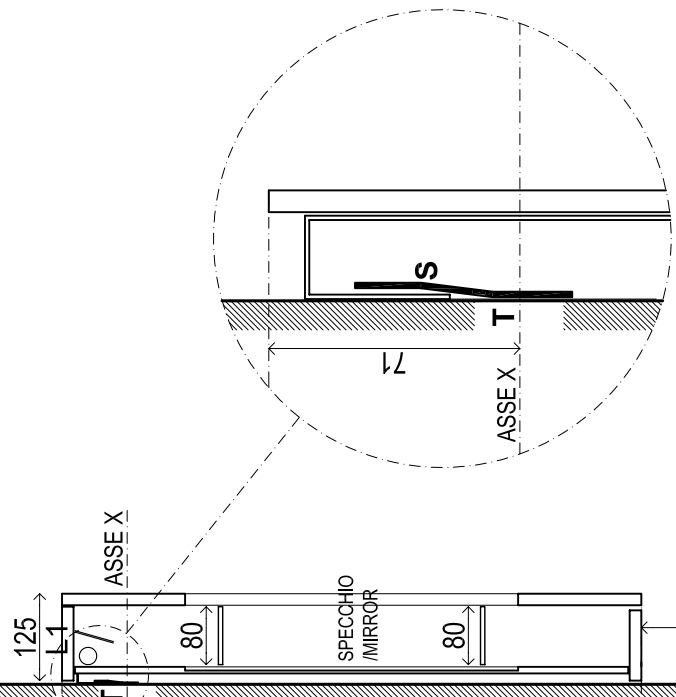
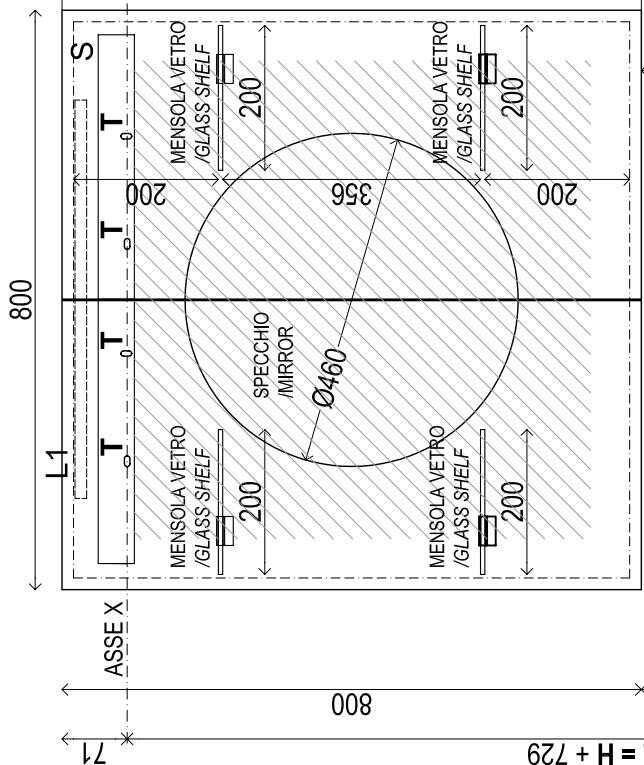

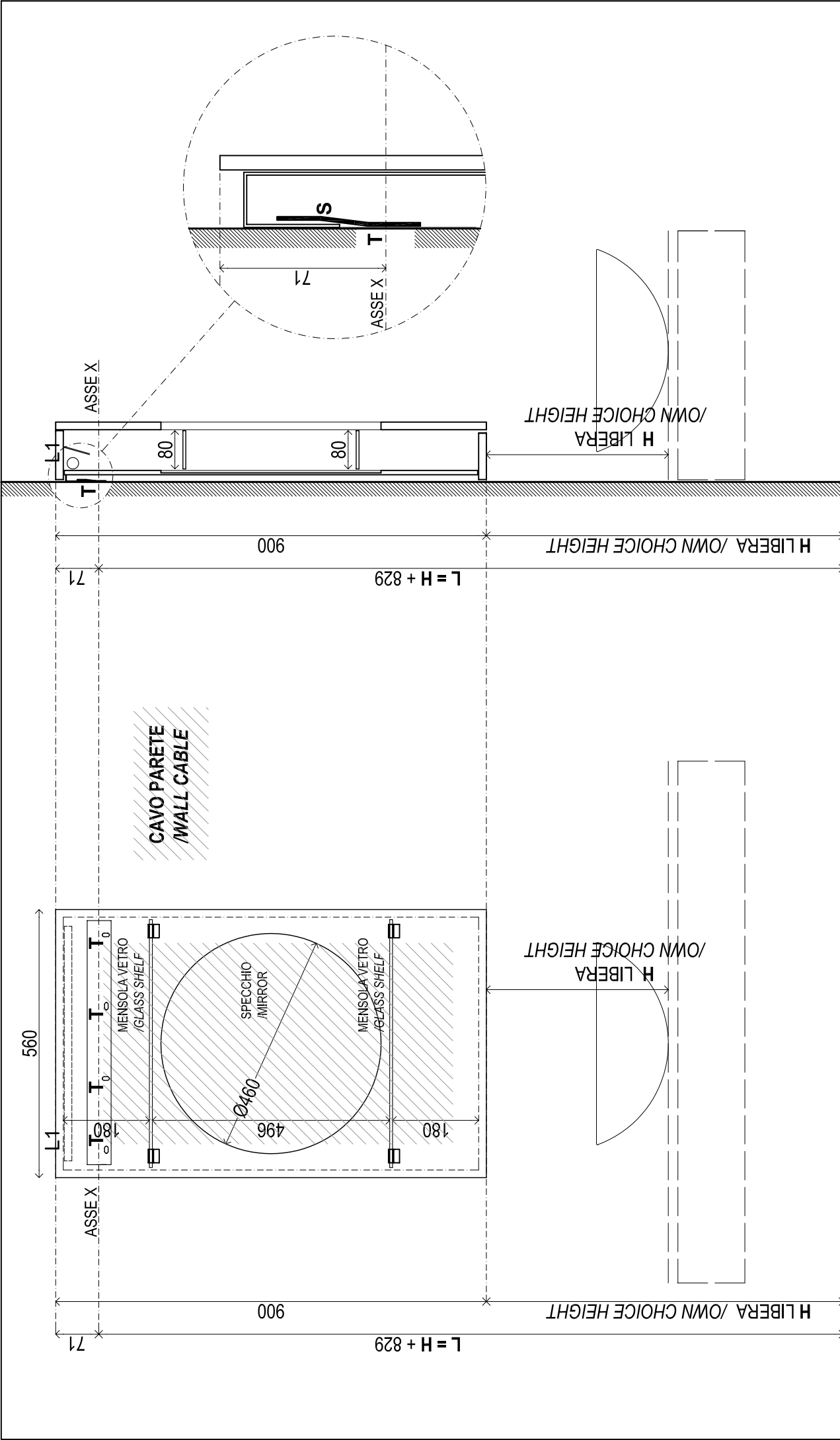

QUOTE IN MM /DIMENSIONS EXPRESSED IN MM

T = TASSELLI /FISHER
 S = STAFFA /BRACKET
 L1 = LAMPADA FLUORESCENTE /MINU' FLUORESCENT LAMP

LEGENDA /LEGEND

BLO'2
 SPECCHIO BLO'2
 BLO'2 MIRROR

TULLI ZUCCARI Srl
 Zona Industriale - 06031 Bevagna (PG)
 Tel 0742-36.20.40 - Fax 0742-36.19.36
 www.tullizuccari.com

ART: 88008

agg 2009 03 21